

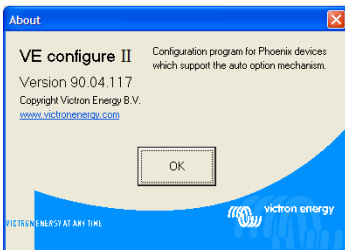

victron energy
BLUE POWER

A guide to using VE configure



option time 1.00 Hr
recharge interval 7.00 Days
recharge time 14 Hr

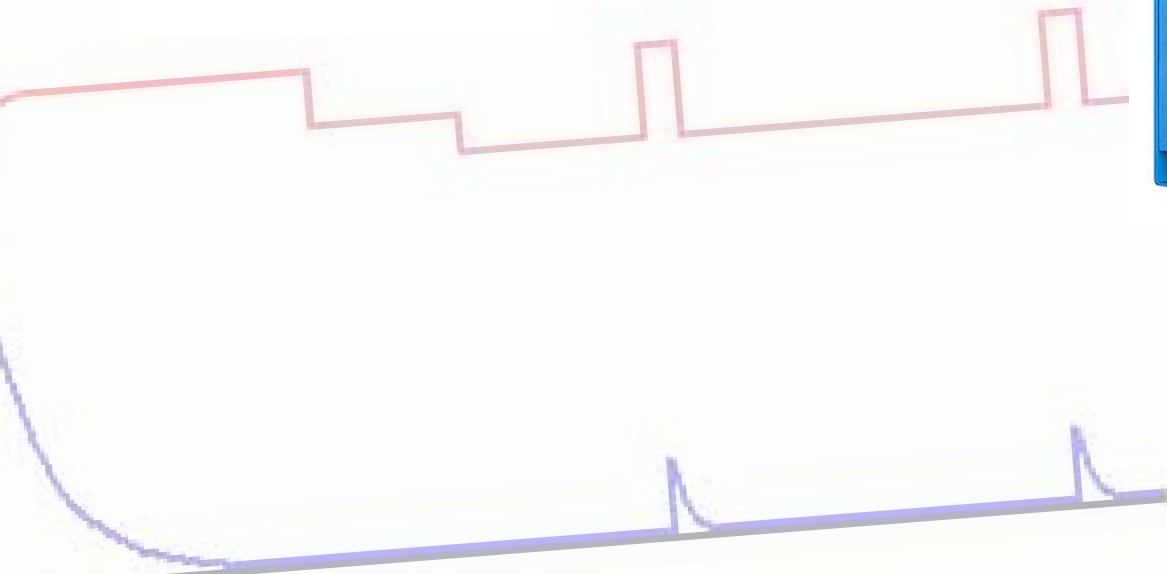
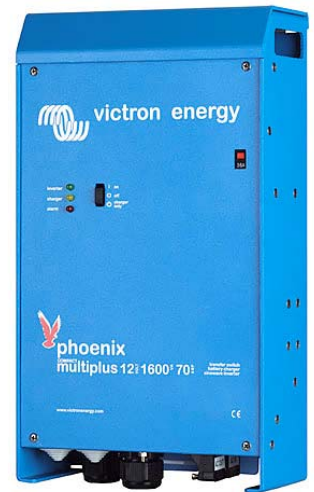

Connecting your Victron product to a computer with VE Configure

It is necessary to know several things before connecting your Victron product to a computer.

- Phoenix Chargers, Phoenix Multi (including Compact) and larger Phoenix Inverters are all compatible with VE configure. All other models are not.
- VE Configure 1 works with software
 1. 14xx100.HEX up to 14xx118.HEX (Phoenix chargers)
 2. All 15xxxxxx.HEX (Phoenix Multis/ Inverters)
 3. 17xx100>HEX up to 17xx129.HEX (Phoenix Multis/ Inverters)
- VE Configure 2 is compatible with newer software versions.
- You can find the software version number on the on the white sticker on the microprocessor on the controller PCB

You can use converter MK1b (or latterly MK2b) to connect the UTP cable (same as the remote control cable) to an available serial COM port on your computer.



Although the VE Configure program still supports MK1b converters we recommend using MK2b or higher. Victron Energy will not give support if you encounter communication problems when using an MK1b.

If you do not have a free COM port, you can use the USB converter to simulate a COM port. Ask your Victron dealer for a suitable adapter cable for this purpose.

To communicate, the Victron unit must be supplied with the appropriate DC voltage.

Chargers	AC
Multi	DC
Multi Compact	DC
Inverters	DC

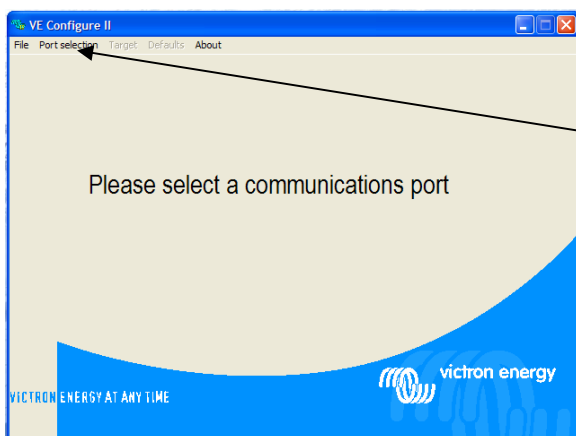

With the software installed, once you have power to the unit, click to select the port to which the converter is connected (often COM 1). There may be some trial and error first time around until you know which port works.

Once the connection is established, the program loads up the information from the connected unit and automatically goes to the first tab, 'General' settings.



Check on the Internet to make sure you have the latest version of the VE Configure software!

If you don't know the function of a specific setting you can use the '*What is this?*' option in the help menu and click on the setting you want information about.

General settings

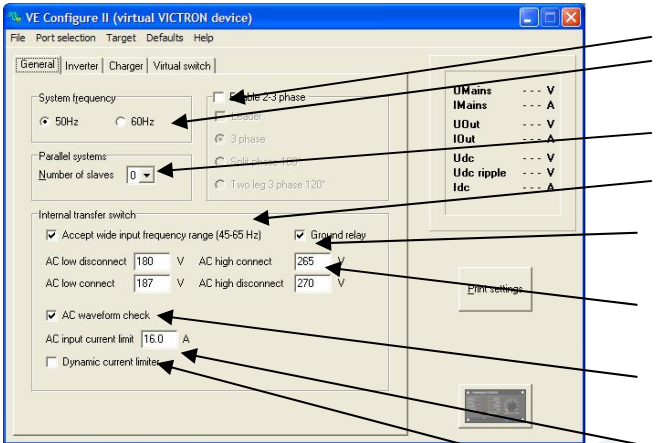

2. Three-phase setting
3. System frequency setting
4. The scale division for shore current limit on a connected remote panel depends on the number of 'slaves'.
5. Set the sensitivity of frequency measurement.
6. Connection between N and PE during inverter operation
7. Voltage limits at which feedback relay opens/closes. Also, charger stops at lower limit.
8. Determines whether the Multi should be critical of the distortion in the supply waveform.
9. Maximum shore current setting (is overruled by the remote panel if connected)
10. Setting for use with 'small' generator



Explanation

1. If multiple devices are connected in parallel, a phase shift can be selected to create 2-, 3- or split-phase configuration. The first unit in a multiple-phase system must be set as the LEADER; the others must be set to the desired phase shift. If multiple units are then also connected in parallel for each phase, no setting should be made on the additional units!
2. Alters the output frequency setting for the inverter.
3. Number of slaves indicates that there are units connected in parallel. To maintain the shore current limit scale on the remote control for the installation as a whole, the setting must be divided between the number of parallel units. If more shore current is available than the scale allows, then an alternative value may be entered. In this case, the scale on the remote is no longer correct and it is possible to draw more current from shore.
4. This setting is used to indicate whether it is necessary for the input frequency to be exactly 50 or 60 Hz. This is a setting that is primarily used in conjunction with generators (speed may not always be stable) to prevent the Multi from rejecting the input supply
5. To permit use of a Residual Current Device (RCD). During operation as an inverter, a connection between PE and N is required.
6. These are the limits at which the unit will accept or reject the supply. If the input voltage drops below the set value of the lower limit, the charger output will be reduced to the minimum to prevent further reduction of the voltage.
7. If waveform detection is deselected, this automatically activates the function preventing the lower voltage limit from being exceeded with heavy start-up loads! (previously labelled 'Allow inrush current')
8. This setting is only active if no system panel is installed. Also keep number 3 in mind!
9. If an inverter-generator is used, such as the HONDA EU series, the shore current setting will be dynamically reduced (following a period of low current consumption) to compensate for the engine reaction time when higher loads are activated.

Inverter settings

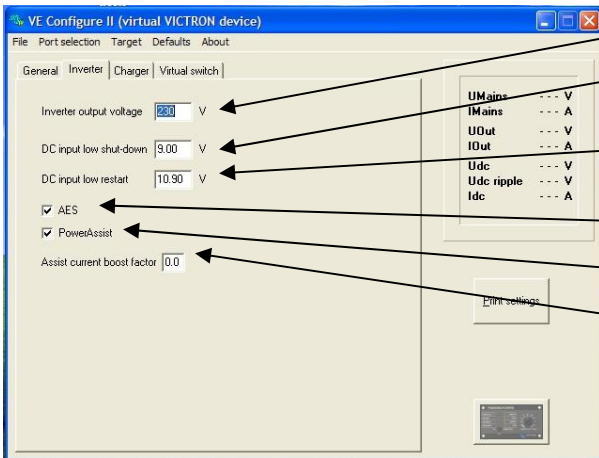

1. To set output voltage of inverter
2. To set the low battery voltage level at which the inverter shuts off
3. To set the voltage at which the inverter restarts after low voltage shut-down.
4. Energy saving setting to conserve power if there is no significant load drawn from the inverter.
5. Activates Power Assist function.
6. The boost factor is the peak power provided by the inverter when the shore current limit is exceeded at start up of heavy loads.



Explanation

1. This is normally 230 Vac.
2. To ensure long battery life, this value must not be set too low.
3. To prevent rapid fluctuation between shut-down and start up, it is recommended that this value be set at least one volt higher than the low battery shut-down voltage.
4. If the system has consumers with high inrush characteristics (such as microwave ovens and air-conditioning) deactivate AES to prevent them from switching on too slowly and causing overload.
5. Use this setting to activate or de-activate the Power Assist feature of MultiPlus.
6. This value is normally set to 2. This is a safe value because any small peak will be compensated by the inverter and the excessive power will not overload the input circuit protection. Be very careful with this setting and change it only once you have carefully considered the possible negative aspects of doing so!



Charger settings

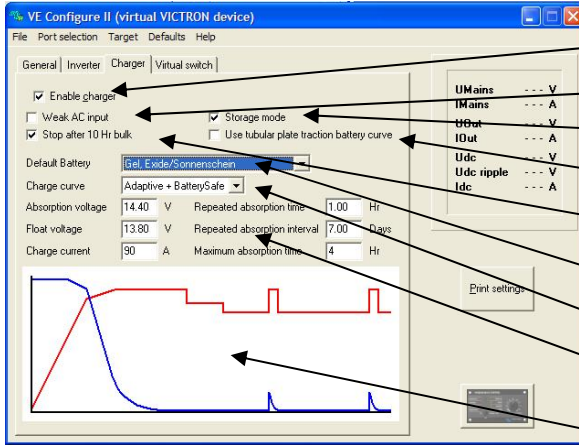

1. To set the charger function on/off
2. To deactivate power-factor compensation
3. To set storage mode on/off
4. Special charge curve for traction batteries
5. Overcharge protection
6. To set pre-programmed battery type
7. To select prescribed charge curve
8. Manual settings for battery charging
9. Graphic representation of selected charge curve



Explanation

1. The inverter and assist functions of the Multi will continue to operate, but it will no longer charge; the charging current is therefore zero!
2. If the quality of the supply waveform is less than the charger expects, it will reduce its output to ensure that the COS phi (difference between current/voltage phases) remains acceptable. This protection can be deactivated for low capacity or poorly regulated power supplies.
3. With this feature active, after 24 hours in float charge, the charging voltage will be reduced below the float voltage to provide optimum protection of the battery against overcharging; charging current will continue to be applied regularly to compensate for self-discharge. This is the rest voltage if the battery is fully charged.
4. For optimum charging, special traction batteries require a fixed charging current phase in addition to a voltage curve. Beware that this often results in a higher charging voltage that can be damaging to regular on-board consumers!
5. If the absorption voltage has not been reached after 10 hours, the battery may be faulty and the charger will switch off for safety reasons.
6. VE Configure is pre-programmed with prescribed charge profiles for different battery types that can be easily selected from the menu.
7. Under normal circumstances always select the adaptive mode. If the balance between the charger and battery is not ideal, it may be better to choose fixed mode otherwise the voltage will rise too quickly or too slowly and the battery may be over or under charged as a result.



Tips and tricks

The charging current should be approximately 15 to 20% of the battery capacity. Also keep in mind the DC consumption that is expected in the system.

For Multi units that are connected in parallel, the current must be set for each Multi! *For a desired battery charging current of 75 A supplied by 3 Multi units, for instance, the setting of the Master must be 25 A!*

Virtual Phoenix panel



The virtual panel works in exactly the same way as the real panel.
If the 'screw head' in the upper-right corner is clicked, the panel can be closed/ hidden.



Tips and tricks

The virtual panel works exactly like the normal Phoenix Multi panel. When used for the first time it may be necessary to switch the Multi off and on before it will respond to the interface.

The virtual panel is only accessible as part of VE Configure and it is necessary to use interface MK1b or MK2b.

This version of the panel is not suitable for use as a Powerman panel! *If a power manager is used, the computer must be connected directly to the Multi and not via the power manager!*



Virtual switch

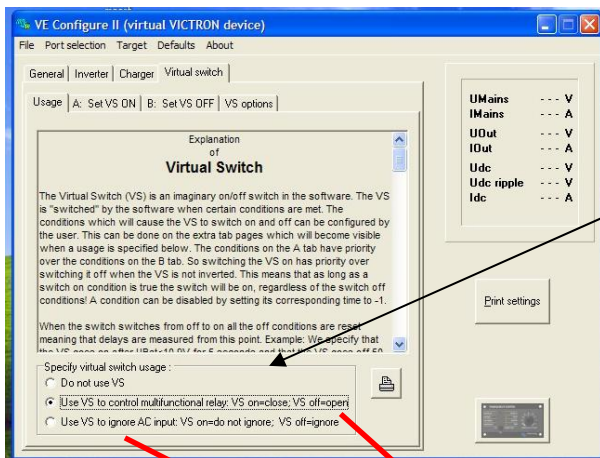

- VS usage options
1. Relay control switched off (tabs are not visible)
 2. Setting for programming of the multifunction relay
 3. Setting for programming of the feedback relay

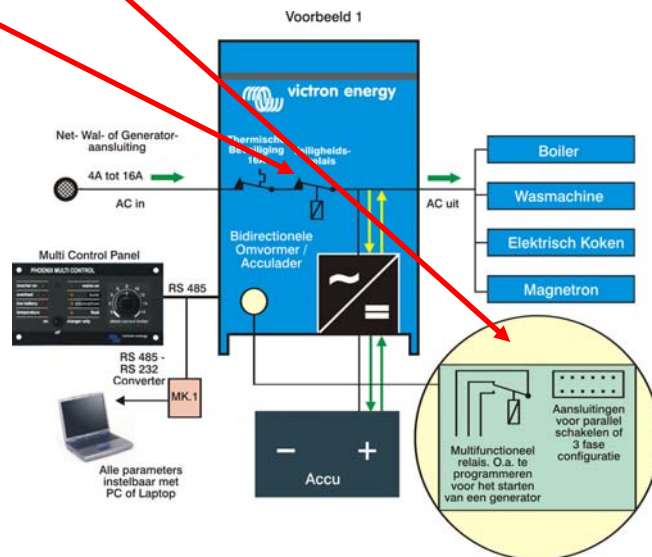

Tips and tricks

It is possible to use VS either to control the multifunction relay (a physical set of changeover contacts) or to control the operation of the feedback relay.

The multifunction relay might be used for alarm or control signals where controlling the feedback relay may be desired for power management in alternative energy applications.



Programming example

Sometimes it is handy to have the Multi or inverter send a signal to a generator to allow it to start automatically. To show how this could be programmed, a practical example is provided below. Suppose the Multi is connected via the multifunction voltage-free relay to the generator.

The conditions under which the generator operates in this example are:

1. start generator if the load exceeds 1000 Watts
2. start generator if the battery voltage drops below 11.75 V
3. start generator if the ripple voltage becomes too high
4. the generator must run for at least 30 minutes after it is started



The connection for the Virtual Switch is located at the top-right of the controller PCB.

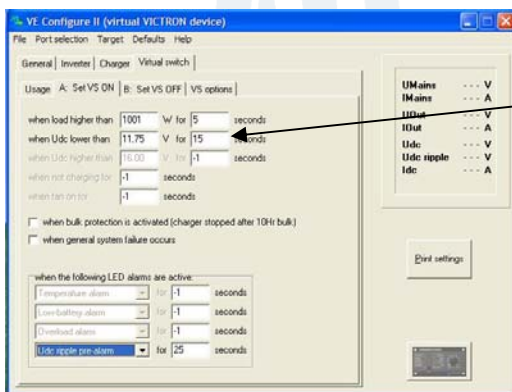

Start-up

To set the desired conditions, the time must be changed from -1 (false=not active) to 0 seconds or higher (value higher than 0 is the response delay!) Thus, in this example [when load higher than]/[when Udc lower than]/[Udc ripple pre-alarm] must all be set to 0 or higher (do not choose alarm because this will cause the Multi to be switched off before the generator is started!)

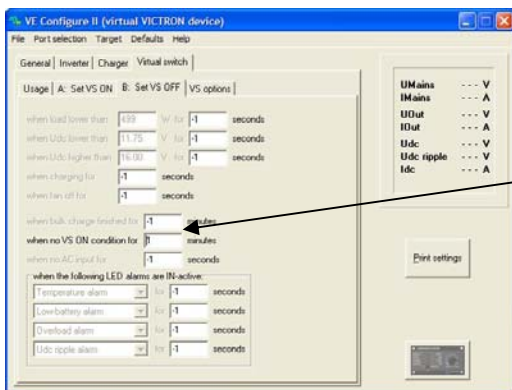

Shut-down

To ensure that the generator shuts-down if the ON condition is no longer present, you can simply use the setting [when no VS ON condition for] and change the value from -1 to 0 or higher. This prevents conflicts between the on and off conditions.

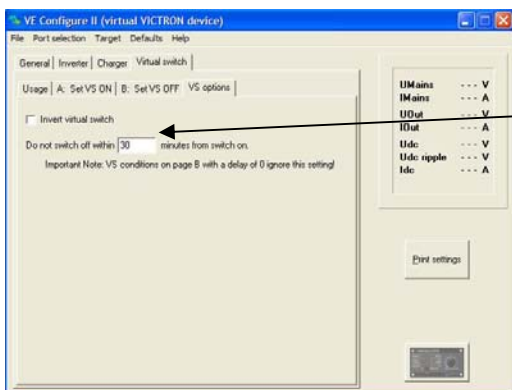

Switching options

To ensure that the generator is not shut-down immediately after it has started, a minimum switching time of, for example, 30 minutes can be selected in the [VS options] tab.

Notes

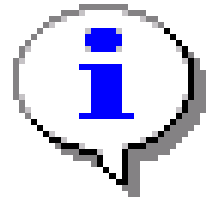

As far as it is possible, switch off all power while working on the system!



Do not touch the exposed internal parts of your Victron unit during operation!



Make sure there are no important loads in operation during programming.



After changing the settings, check performance with a multimeter.

Saving/loading settings

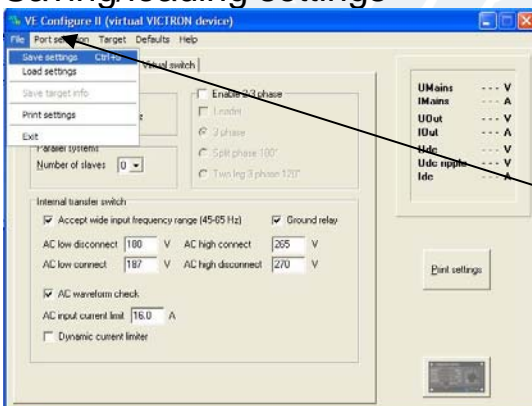

It is possible to save the settings on your computer, open the File menu and select [*Save settings Ctrl+F5*].



Choose a logical name for the settings file, such as the name of the vessel, vehicle or other application.

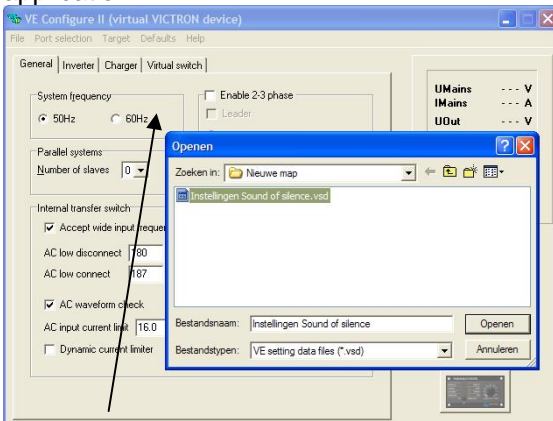

To use the settings saved in the computer, select the option [*Load settings*] from the same menu. Do not forget to send the settings to the Victron with [*send settings*].

What to do if...



Error message when you attach the communication cable

Check whether the unit is suitable for configuration through a computer.
(Phoenix Charger / Phoenix Multi (including compact / larger Phoenix Inverter))

Check whether the software on the PC is compatible with the internal software of the Victron.
(VE Config 1 with DAT file for software version lower than xxxx 130).

Check the cabling (the communication cable is a straight-through cable, not a cross-over cable).



After making adjustments the Victron unit does not work as it should.

In the [Defaults] menu, select [Set all settings to default] to restore the factory settings and try again.

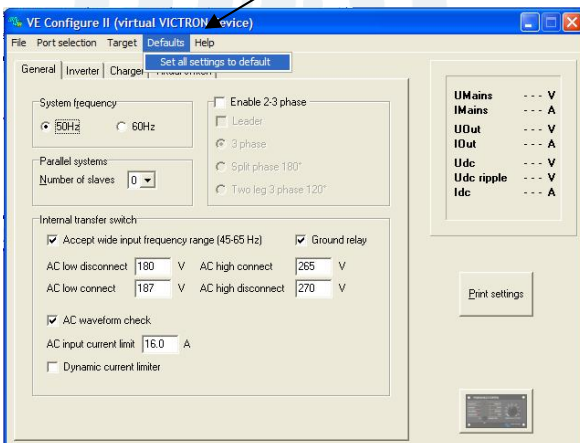

If you have additional questions or comments after reading this document, do not hesitate to contact us at sales@victronenergy.com or contact your local Victron Energy dealer.